

Brief Operation Manual

GTYQ-IR500L

**Fixed-Type Combustible
Gas Detector for Industrial
and Commercial Use**



CONTENTS

1、	Electrical Connection and Commissioning.....	2
1.1、	Electrical Connection	2
2、	Operating Instructions.....	3
2.1、	Control Panel and Adjustment Tools	3
2.2、	Remote Control Buttons and Functions.....	3
2.3、	Information Query.....	3
2.4、	Parameter Settings.....	3
2.5、	Zero Calibration Settings	4
2.6、	Span Calibration Settings	4
3、	Common Faults and Troubleshooting Methods	6

1、 Electrical Connection and Commissioning

1.1、 Electrical Connection

Wiring Configuration for Connection Cable and Internal Terminal Block (see diagram below):

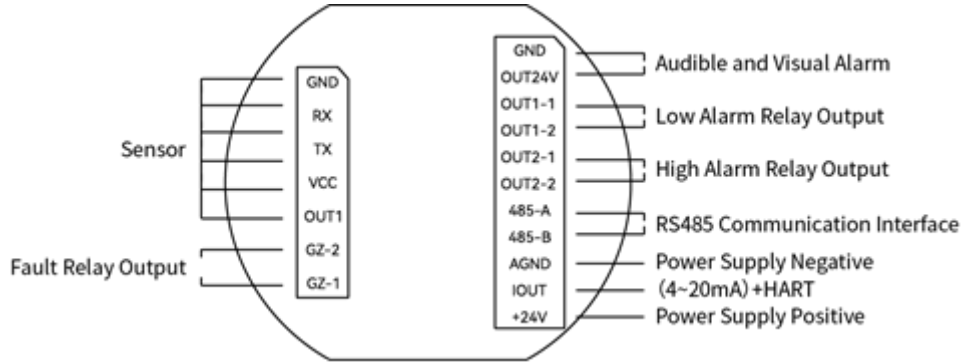

Terminal Block Diagram

Correspondence between Connection Cable and Terminal Block (as shown in the table below)

Function	Terminal Designation	Terminal Description	
Relay Output	OUT2-1	Forms high alarm dry contact; terminals AH-2 and AH-1 close when activated; outputs when detector status is high alarm or over-range	
	OUT2-2		
	OUT1-1	Forms low alarm dry contact; terminals AL-2 and AL-1 close when activated; outputs when detector status is low alarm	
	OUT1-2		
	GZ-1	Forms fault dry contact; terminals GZ-2 and GZ-1 close when activated; outputs when detector status is fault	
	GZ-2		
Audible and Visual Alarm	GND	Audible and visual alarm ground	These two terminals provide active switch output at +24V when activated; outputs +24V to drive audible and visual alarm when detector status is low alarm, high alarm, or over-range
	OUT24V	Audible and visual alarm power supply (+24V)	
RS485	485-A	RS485 communication Line A	These two terminals are MODBUS RS485 communication A and B lines
	485-B	RS485 communication Line B	
	JP1	RS485 bus termination resistor selection	
Power(4-20)mA Output	GND	System power ground	
	IOUT	(4-20) mA output	
	+24V	System power line; connect to +24V power supply	
Sensor	GND	Sensor signal ground terminal	
	RX	Sensor communication receive terminal	
	TX	Sensor communication transmit terminal	
	VCC	Sensor signal power supply terminal	
	OUT1	Heater power supply terminal	

2、 Operating Instructions

2.1、 Control Panel and Adjustment Tools

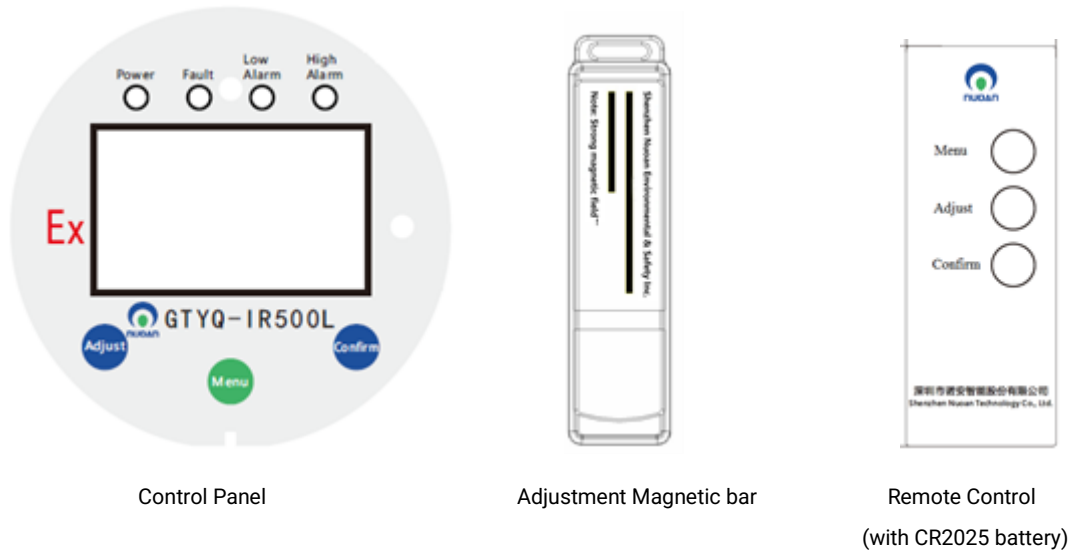

Control Panel Diagram and Adjustment Tools Diagram

2.2、 Remote Control Buttons and Functions

Menu Button: Performs different functions depending on the current display interface. In operation menu mode, it corresponds to the left function key shown at the bottom of the display interface.

Adjust Button: Performs different functions depending on the current display interface. In operation menu mode, it corresponds to the middle function key shown at the bottom of the display interface.

Confirm Button: Performs different functions depending on the current display interface. In operation menu mode, it corresponds to the right function key shown at the bottom of the display interface.

2.3、 Information Query

In normal detection mode, press the "Adjust" key to enter the operational display interface mode. Follow the on-screen prompts and press the "Adjust" key to query various information items, cycling through the options as shown in the diagram below.

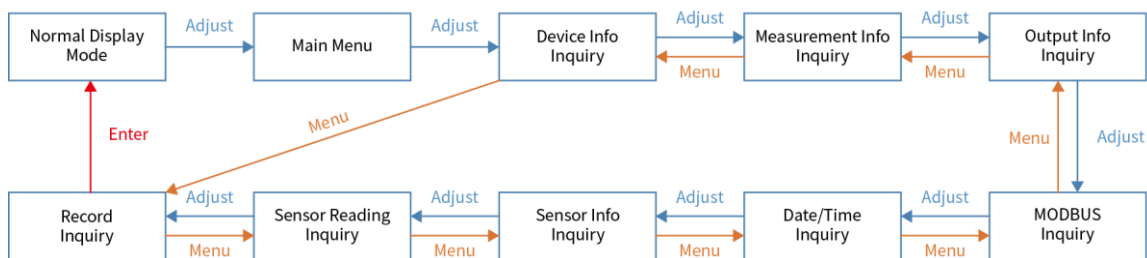

Information Query Diagram

2.4、 Parameter Settings

In normal detection mode, press the "Adjust" key to enter the operational display interface mode. Follow the on-screen prompts and press the "Confirm" key to access parameter settings for various operating modes, cycling through the options as shown in the diagram below (password: "0000").

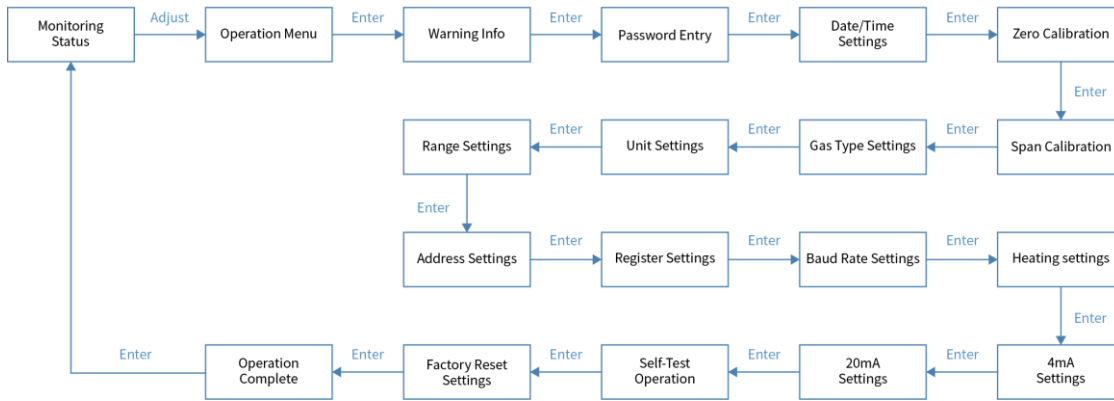

Parameter Settings Diagram

2.5、 Zero Calibration Settings

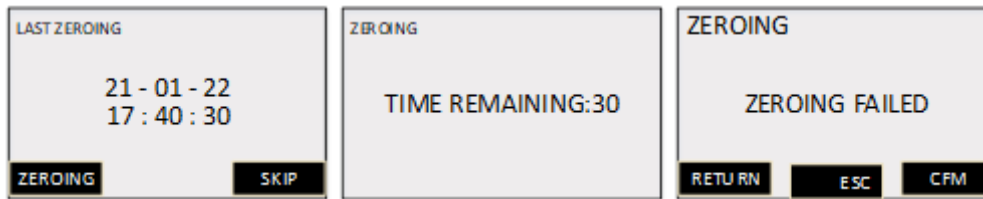

Press the Menu button to initiate zero calibration. Upon successful zero calibration, press the Confirm button to proceed to the next settings display interface. If zero calibration fails, the corresponding failure reason or error code will be displayed.

Causes of Zero Calibration Failure and Troubleshooting Methods (as shown in Table 5 below)

No.	Failure Cause	Remedy
1	Ambient air contaminated; target gas or interfering gas present	Relocate detector to clean air environment and recalibrate zero
2	Sensor failure	Replace sensor and recalibrate zero

2.6、 Span Calibration Settings

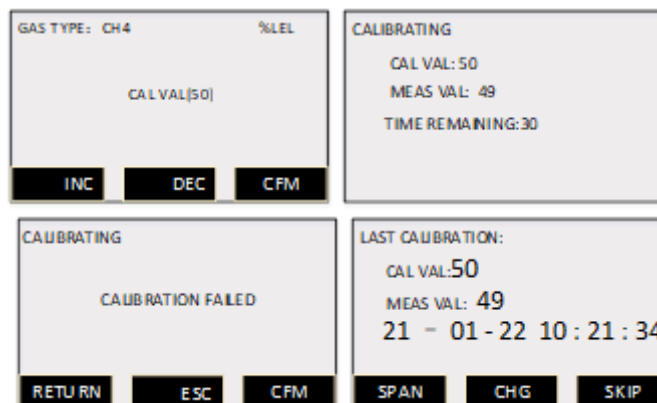

On the span calibration settings display interface, press the Change key to modify the current span gas concentration value, then press Calibrate to initiate calibration. Upon successful calibration, press the Confirm key to proceed to the next settings display interface. If calibration fails, the corresponding failure reason or error code will be displayed.

Note: When performing calibration, you must use the calibration hood supplied by our company. The standard gas must not be removed and the calibration hood must not be taken off until calibration is complete.

(1) Calibration Methods:

Laboratory Mixing Chamber Calibration: Place the detector steadily inside the mixing chamber and allow it to enter normal monitoring mode. Seal the chamber and introduce gas at 50%–80% of full scale. Once the detector reading stabilizes (approximately 3 minutes), proceed with calibration.

On-site Calibration Using Calibration Hood: Allow the detector to enter normal monitoring mode. Fit the calibration hood supplied by our company over the protective cover of the sensor assembly and ensure it is properly seated. Then introduce gas at 50%–80% of full scale through the air inlet nozzle on the protective cover. Once the detector reading stabilizes (approximately 3 minutes), proceed with calibration. After calibration is complete, remove the gas delivery tube and the calibration hood.

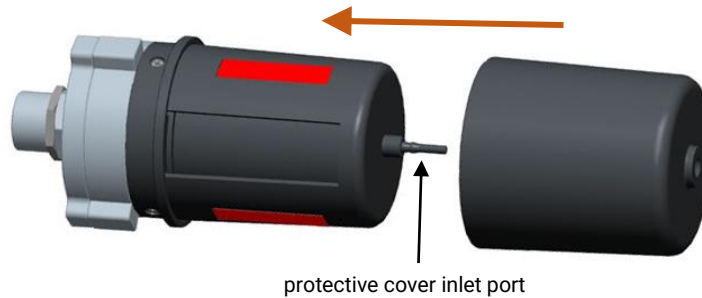

Installation and Calibration Cover Diagram

(2) T90 Response Time Test Method:

Bring the detector into normal monitoring status. Fit the "calibration cover" (supplied by our company) onto the protective housing of the sensor assembly and ensure it is properly assembled. Then, introduce test gas at a flow rate of 500 mL/min and a concentration of 60% of full scale into the inlet nozzle of the sensor assembly's protective housing. Maintain this condition for 60 seconds and record the displayed value as the reference value. The time required for the displayed value to reach 90% of the reference value is the response time of the sensor.

(3) Causes of Calibration Failure and Remedial Actions (as shown in the table below)

No.	Cause of Failure	Remedial Action
1	Inaccurate standard gas concentration or excessive error	Verify standard gas concentration and recalibrate
2	Sensor failure	Replace sensor and recalibrate

3、 Common Faults and Troubleshooting Methods

No.	Fault or Error Indication	Cause	Solution
1	Power on but cannot start	Poor contact or incorrect connection of DC24V power cable	Check and correctly connect the DC24V power cable
		Detector malfunction, self-resetting fuse tripped due to overcurrent	Contact manufacturer for repair or replacement
2	LCD displays garbled characters or missing segments	LCD panel damaged	Contact manufacturer for repair or replacement
		Main chip damaged	Contact manufacturer for repair or replacement
		System freeze	Turn off power and restart
3	Backlight flashing continuously	Ambient light at critical threshold for backlight activation	Wait for ambient light to dim
		Internal component damaged	Contact manufacturer for repair or replacement
4	No response from remote control operation	Incorrect operation method	Operate correctly according to user manual
		Remote control battery depleted	Replace with new battery (CR2025)
		Internal component damaged	Contact manufacturer for repair or replacement
5	No response or slow response	Sensor assembly vent holes blocked	Clean vent holes on flameproof disc surface of sensor assembly
		Sensor aging or failure	Replace sensor
6	Communication fault	Incorrect wiring of sensor assembly	Check connection cable and correctly connect sensor assembly
		Detector connection cable short circuit, open circuit, or incorrect wiring	Check connection cable and correctly connect detector
		Detector circuit malfunction	Contact authorized service provider for repair or replacement
7	Light source damaged	Sensor aging or failure	Contact authorized service provider for repair or replacement
8	Light energy too low		
9	Detection channel circuit fault		
10	Reference channel circuit fault		
11	Temperature too high		
12	Temperature too low		



Follow NUOAN Technology official WeChat account for more updates

Unit: Shenzhen NUOAN Technology Co., Ltd.

Postcode: 518107

Office Address: 13-16/F, Building C1, No. 459 QiaoKai Road, FengHuang Community, FengHuang Street, GuangMing District, ShenZhen

Production Address: 13-15/F, Building C1, No. 459 QiaoKai Road, FengHuang Community, FengHuang Street, GuangMing District, ShenZhen

Tel: 0755-26826466 26827266

Fax: 0755-26826366

Website: nuoandetector.com

Email: sales@nuoan.com

Version: V1.2

Compilation Date: January 15, 2026

※ The manufacturer reserves the right to modify and improve the products described in this manual at any time without prior notice.