

Brief Operation Manual

GTYQ-SNE4100B

Industrial & Commercial Fixed-Type Combustible Gas Detector



 深圳市诺安智能股份有限公司
SHENZHEN NUOAN TECHNOLOGY CO., LTD.

All Rights Reserved.
Reproduction Prohibited



CONTENTS

1、Electrical Connection	2
2、Operation Methods	3
2.1、Introduction to Operating Tools	3
2.2、IR Remote Control Button Description	3
2.3、Parameter Settings	3
2.4、Zero Adjustment	4
2.5、Span Calibration	5
3、Common Faults and Trouble shooting	6

1、Electrical Connection

The wiring diagram for connecting the cable to the internal terminal block is shown below:

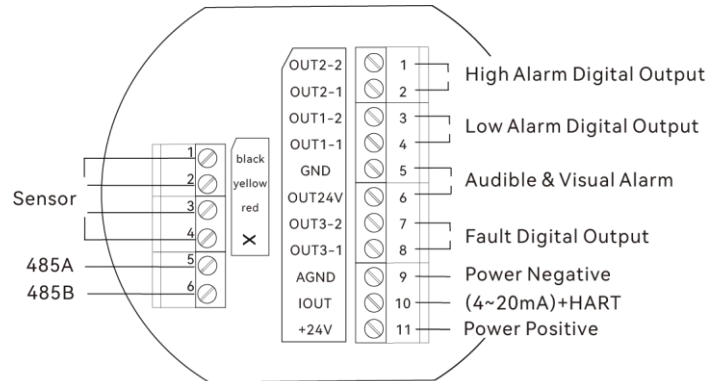

Terminal block diagram
Figure 1: Wiring Terminal Diagram

Correspondence between Connection Cables and Wiring Terminals (see table below) :

Function	Terminal	Terminal description	
Digital Output	OUT2-2	OUT2-2 and OUT2-1 form High Alarm passive digital output 2: terminals OUT2-2 and OUT2-1 close when activated.	
	OUT2-1	Output 2 activates when detector status is High Alarm or Over Range.	
	OUT1-2	OUT1-2 and OUT1-1 form Low Alarm passive digital output 1: terminals OUT1-2 and OUT1-1 close when activated.	
	OUT1-1	Output 1 activates when detector status is Low Alarm, High Alarm, or Over	
	OUT3-2	OUT3-2 and OUT3-1 form Fault passive digital output 3:	
	OUT3-1	terminals OUT3-2 and OUT3-1 close when activated.	
Audible & Visual Alarm	GND	Audible & visual alarm ground	These two terminals are active digital output, providing +24V when activated. +24V is output to drive the audible & visual
	OUT24V	Audible & visual alarm power	
RS485	485B	RS485 communication Line B	These two terminals are MODBUS RS485 communication A and B lines.
	485A	RS485 communication Line A	
Power / 4-20mA Output	AGND	System power ground	
	IOU	4-20mA output	
	+24V	System power line, connect to +24V power supply	
Sensor	X	Indicates this terminal is temporarily unused; do not connect any wiring.	
	Red	Sensor power terminal, corresponding to red wire on sensor component	
	Yellow	Sensor concentration signal terminal, corresponding to yellow wire on sensor	
	Black	Sensor ground terminal, corresponding to black wire on sensor component	

2、Operation Methods

2.1、Introduction to Operating Tools

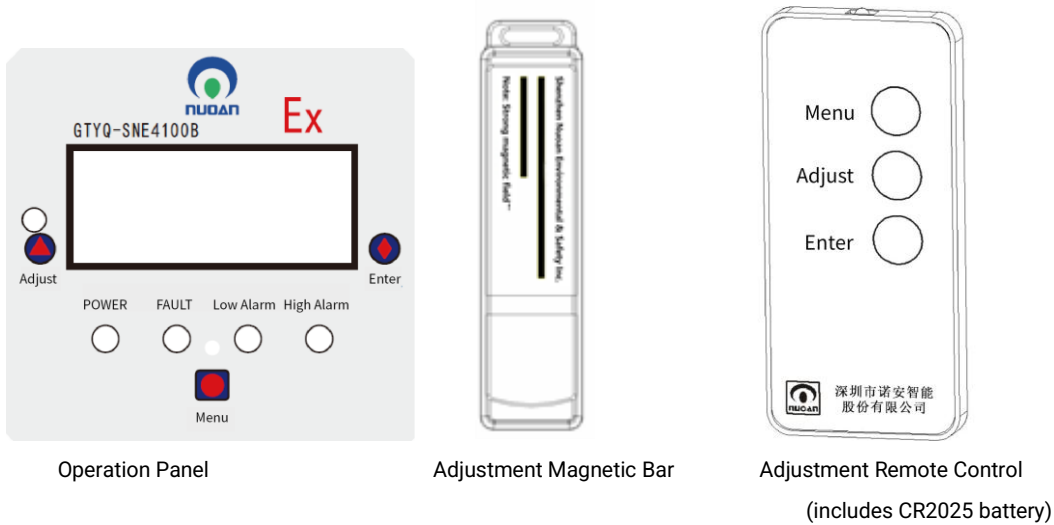

Figure 2: Operation Panel Diagram and Adjustment Tools

2.2、IR Remote Control Button Description

- Menu (●): Operation mode conversion key. Each press changes the operation mode once.
- Adjust (▲): Press to adjust the parameter value in current mode. Pressing Adjust decreases the value; combine with Menu button to increase, enabling bidirectional adjustment.
- Confirm (◆): Confirm and exit. Saves current settings or returns to normal detection mode.

2.3、Parameter Settings

Press the Menu button in normal detection mode to access parameter settings for various operation modes. The cycle is shown in Figure 3 below. For specific setting methods, refer to Table 2 Operation Instructions. (※ Note: Automatically returns to normal detection mode if no operation is performed within 30 seconds.)

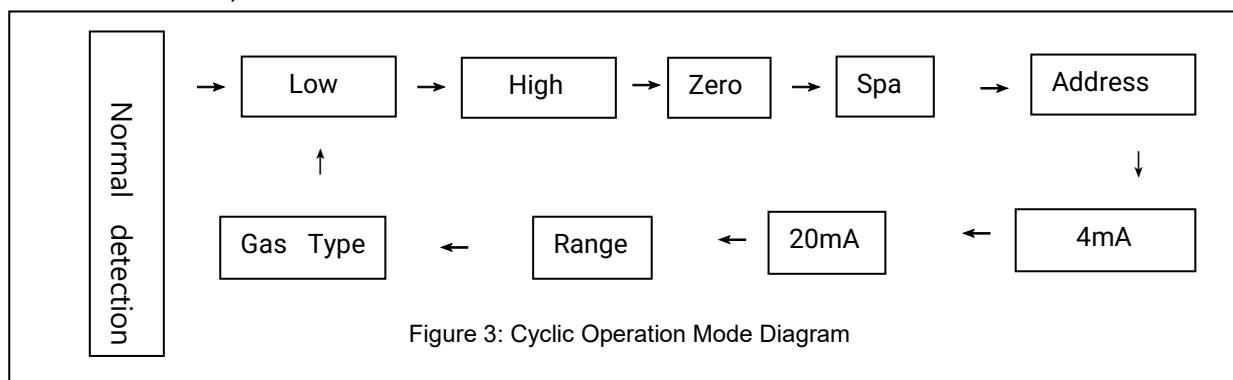

Figure 3: Cyclic Operation Mode Diagram

Parameter Name	Selection Method	Menu Code	Setting Method	Setting Range	Setting Confirmation
Low Alarm Setting		LA	Press Adjust key to start:	Combustible gas: 5~25%LEL	
High Alarm Setting		HA	Adjust key to decrease: Menu key to increase: Value cycles upward	Per relevant standards, combustible gas high alarm point factory default is 50%LEL	
Zero Adjustment		A0	Press Adjust key to start	Not adjustable	
Calibration		A1	Refer to "10.5.4 Calibration"	Combustible gas: 20~60%LEL	
Address Setting		A2	Refer to "10.5.5 Address"	1 ~ 127	
4mA Calibration		A4	Press Adjust key to start;	0 ~ 99	
20mA Calibration		A20	Adjust key to decrease; Menu key to increase;	0 ~ 255	
Range Selection		Range	Press Adjust key to query	Combustible gas 100%LEL, not adjustable	
Gas Type Selection		type	Refer to "10.5.9 Gas Type"	Select correct measurement gas type per prompt	

2.4、Zero Adjustment

For zero adjustment, first ensure that the sensor is in clean air. Press the Menu button until the display shows "A0" – Zero Adjustment Mode. The display is shown in Figure 3.



Figure 3

Press the Adjust key, and the detector will automatically perform zero adjustment. The display will flash showing "- 0 -", as shown in Figure 4.



Figure 4

After 10 seconds, "YES" will be displayed indicating successful zero adjustment. Press the Confirm key to return to normal detection mode; if "E02" appears, it indicates zero adjustment failure. The display is shown in Figure 5 or Figure 6.



Figure 5



Figure 6

Note: "YES" indicates successful zero adjustment; "E02" indicates zero adjustment failure.

Causes of Zero Adjustment Failure and Solutions (as shown in the table below)

No.	Cause of Failure	Solution
1	Ambient air is not clean, with detection gas or interfering gas present	Move the detector to a clean air environment and perform zero adjustment again
2	Sensor failure	Replace the sensor and perform zero adjustment again

2.5、Span Calibration

In normal detection mode, apply standard gas (standard gas concentration range: 20%~60% F.S.) to the sensor through the "calibration hood" at a flow rate of 500 mL/min. Maintain the gas flow for approximately one minute until the data displayed on the screen stabilizes. Press the Menu button until the display shows "A1" – Calibration Mode. The display is shown in Figure 7.



Figure 7

Press the Adjust key, and the display will show the previous calibration confirmation value (default factory calibration for combustible gas is generally "50").

If the standard gas currently used is inconsistent with the last calibration value, press the Adjust key to decrease the displayed value, or press the Menu key to increase the displayed value, until the value shown on the display matches the current standard gas concentration. Then press the Confirm key to execute calibration. The display will flash showing "- A -" as shown in Figure 8.

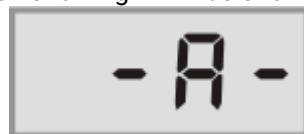

Figure 8

After 10 seconds, "YES" will be displayed indicating successful calibration. Press the Confirm key to return to normal detection mode; if "E03" appears, it indicates calibration failure. The display is shown in Figure 9 or Figure 10.



Figure 9



Figure 10

Note: "YES" indicates successful calibration; "E03" indicates calibration failure.

※ Note: During span calibration, do not remove the standard gas until calibration is completed.

Causes of Calibration Failure and Solutions (as shown in the table below)

No.	Cause of Failure	Solution
1	Inaccurate standard gas concentration, excessive error	Check standard gas concentration and recalibrate
2	Sensor failure	Replace the sensor and recalibrate

3、Common Faults and Trouble shooting

No.	Fault or Error Indication	Cause	Solution
1	Cannot power on	Poor contact or wrong connection of DC24V power cable	Check and correctly connect DC24V power cable
		Detector fault, self-recovery fuse disconnected due to overcurrent	Contact manufacturer for repair or replacement
2	LCD displays garbled characters or missing segments	LCD panel damaged	Contact manufacturer for repair or replacement
		Main chip damaged	Contact manufacturer for repair or replacement
		System freeze	Turn off power and restart
3	Backlight flashes continuously	Ambient light at backlight activation threshold	Continue waiting for ambient light to dim
		Internal component damaged	Contact manufacturer for repair or replacement
4	No response to magnetic bar or remote control operation	Incorrect operation method	Operate correctly according to user manual
		Remote control battery depleted	Replace with new battery (CR2025)
		Internal component damaged	Contact manufacturer for repair or replacement
5	No response or slow response	Sensor component vent hole blocked	Clean vent hole on sensor component flameproof disc surface
		Sensor aging or failure	Replace sensor
6	E01	Sensor component wiring error	Check connection cable and correctly connect sensor component
		Zero point voltage abnormal	Adjust zero point voltage
		Detector connection cable short circuit, open circuit or wiring error	Check connection cable and correctly connect detector
		Detector circuit fault	Contact authorized service provider for repair or replacement
7	E02	Ambient air not clean, with detection gas or interfering gas present, zero adjustment failed	Move detector to clean environment and perform zero adjustment again
		Zero adjustment failed, sensor aging or failure	Replace sensor component and perform zero adjustment again
8	E03	Inaccurate calibration test gas, concentration out of calibration range, calibration failed	Replace with standard gas within calibration range and recalibrate
		Sensor aging or failure, calibration failed	Replace sensor component and recalibrate
9	OUL	Gas concentration exceeds range by more than 20%	Reduce gas concentration
		Detector circuit board fault	Contact authorized service provider for repair or replacement



Follow NUOAN technology official WeChat public account for more information

Company: Shenzhen NUOAN Technology Co., Ltd.

Postcode: 518107

Office Address: 16/F, Building C1, No. 459 QiaoKai Road, FengHuang Community, FengHuang Street, GuangMing District, ShenZhen

Factory Address: 13-15/F, Building C1, No. 459 QiaoKai Road, FengHuang Community, FengHuang Street, GuangMing District, Shenzhen

Tel: 0755-26826466 26827266

Fax: 0755-26826366

Website: nuoandetector.com

Email: sales@nuoan.com

Version: V1.0.2

Compilation Date: January 15, 2026

※ The manufacturer reserves the right to modify and improve the products described in this manual at any time without prior notice.